

ML Maximum Power Point Tracking (MPPT) Series ML2420-ML2430-ML2440 Solar Charge and Discharge Controller



Product Features

- With the advanced dual-peak or multi-peak tracking technology, when the solar panel is shadowed or part of the panel fails resulting in multiple peaks on the I-V curve, the controller is still able to accurately track the maximum power point.
- A built-in maximum power point tracking algorithm can significantly improve the energy utilization efficiency of photovoltaic systems, and raise the charging efficiency by 15% to 20% compared with the conventional PWM method.
- A combination of multiple tracking algorithms enables accurate tracking of the optimum working point on the I-V curve in an extremely short time.
- The product boasts an optimum MPPT tracking efficiency of up to 99.9%.
- Advanced digital power supply technologies raise the circuit's energy conversion efficiency to as high as 98%.
- Charging program options are available for different types of batteries including gel batteries, sealed batteries, open batteries, lithium batteries, etc.
- The controller features a limited current charging mode. When the solar panel power exceeds a certain level and the charging current is larger than the rated current, the controller will automatically lower the charging power and bring the charging current to the rated level.
- Instantaneous large current startup of capacitive loads is supported.
- Automatic recognition of battery voltage is supported.
- LED fault indicators and an LCD screen which can display abnormality information help users to quickly identify system faults.
- Historical data storage function is available, and data can be stored for up to a year.
- The controller is equipped with an LCD screen with which users can not only check device operating data and statuses, but also modify controller parameters.
- The controller supports standard Modbus protocol, fulfilling the communication needs of various occasions.
- The controller employs a built-in over-temperature protection mechanism. When temperature surpasses the set value, the charging current will decline in linear proportion to the temperature so as to curb the temperature rise of the controller, effectively keeping the controller from being damaged by overheat.
- Featuring a temperature compensation function, the controller can automatically adjust charging and discharging parameters in order to extend the battery's service life.
- TVS lightning protection.

Wiring diagram is as below

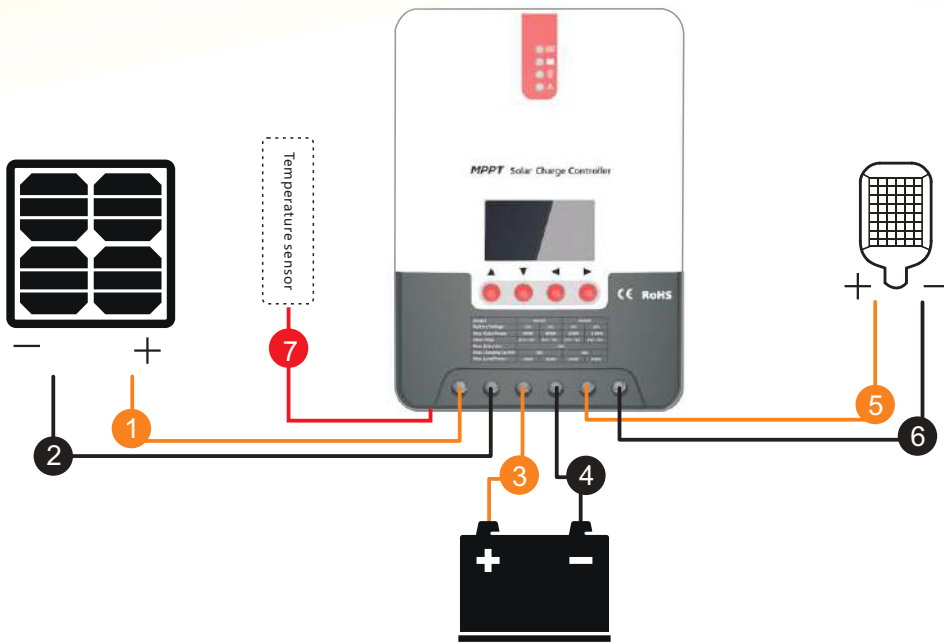



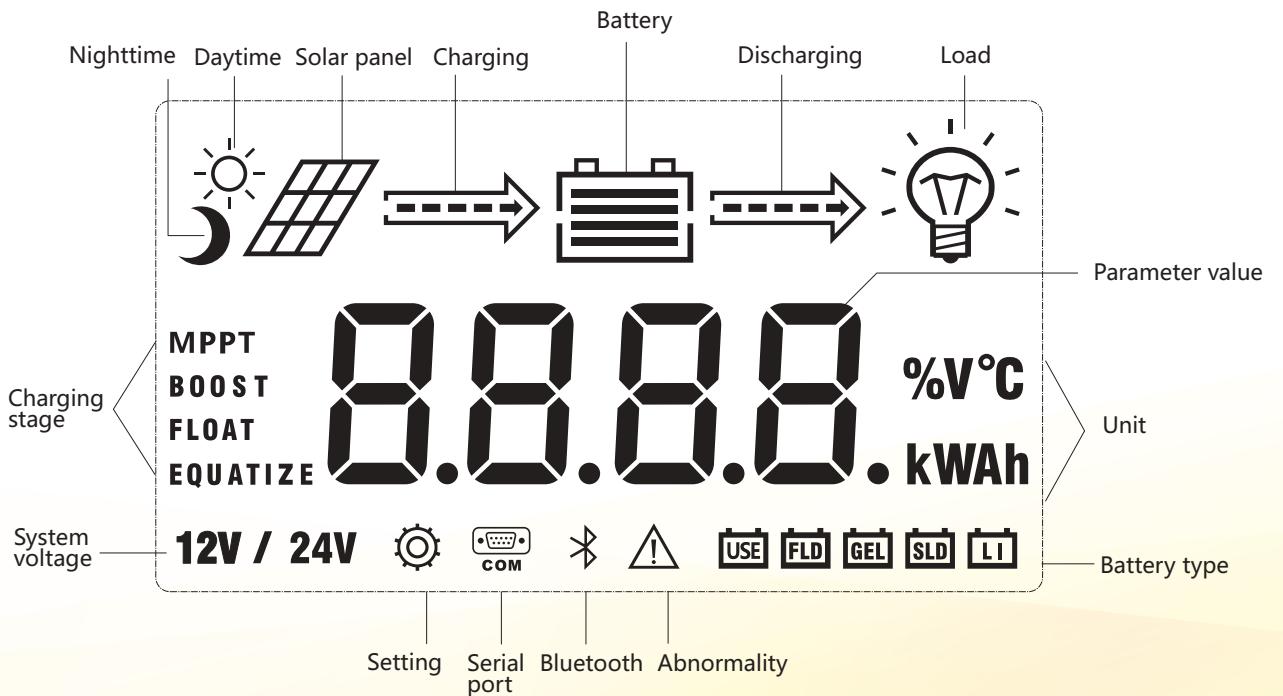





LCD Startup and Main Interface





Product Operation and Display

LED Indicators

| | | | |
|---|---|--------------------|--|
|  |  | PV array indicator | Indicating the controller's current charging mode. |
|  |  | BAT indicator | Indicating the battery's current state. |
|  |  | LOAD indicator | Indicating the loads' On/ Off and state. |
|  |  | ERROR indicator | Indicating whether the controller is functioning normally. |

➤ PV array indicator:

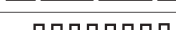
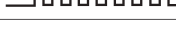
| No. | Graph | Indicator state | Charging state |
|-----|---|--|--------------------------|
| ① |  BULK | Steady on | MPPT charging |
| ② |  ACCEPTANCE | Slow flashing (a cycle of 2s with on and off each lasting for 1s) | Boost charging |
| ③ |  FLOAT | Single flashing (a cycle of 2s with on and off lasting respectively for 0.1s and 1.9s) | Floating charging |
| ④ |  EQUALIZE | Quick flashing (a cycle of 0.2s with on and off each lasting for 0.1s) | Equalizing charging |
| ⑤ |  CURRENT-LIMITED | Double flashing (a cycle of 2s with on for 0.1s, off for 0.1s, on again for 0.1s, and off again for 1.7s) | Current-limited charging |
| ⑥ | | Off | No charging |

➤ BAT indicator:

| Indicator state | Battery state |
|--|-------------------------|
| Steady on | Normal battery voltage |
| Slow flashing (a cycle of 2s with on and off each lasting for 1s) | Battery over-discharged |
| Quick flashing (a cycle of 0.2s with on and off each lasting for 0.1s) | Battery over-voltage |





➤ LOAD indicator:

| Indicator state | Battery state |
|--|----------------------------------|
| Off | Load turned off |
| Quick flashing (a cycle of 0.2s with on and off each lasting for 0.1s) | Load overloaded/ short-circuited |
| Steady on | Load functioning normally |

➤ ERROR indicator:

| Indicator state | Battery state |
|-----------------|---------------------------|
| Off | System operating normally |
| Steady on | System malfunctioning |

Key Operations

| | | |
|---|--------|---|
|  | Up | Page up; increase the parameter value in setting |
|  | Down | Page down; decrease the parameter value in setting |
|  | Return | Return to previous menu (exit without saving) |
|  | Set | Enter into sub-menu; set/ save Turn on/ off loads (in manual mode) |

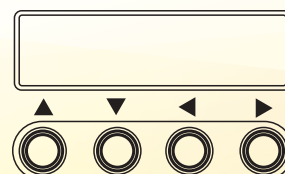

Product Dimensions

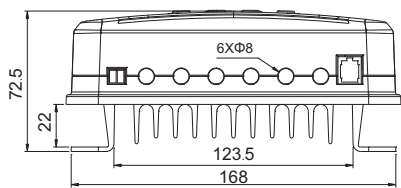
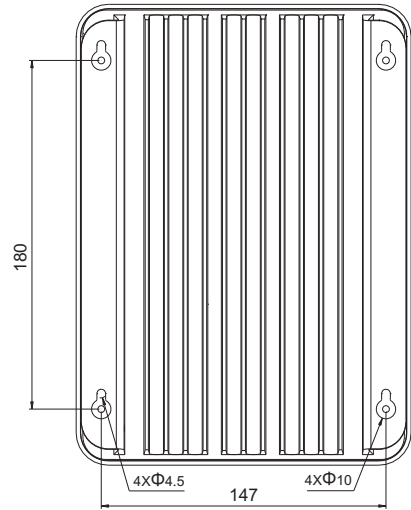
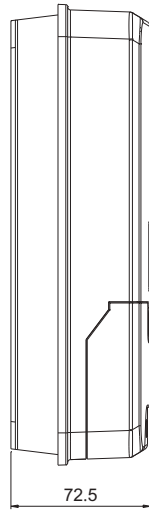
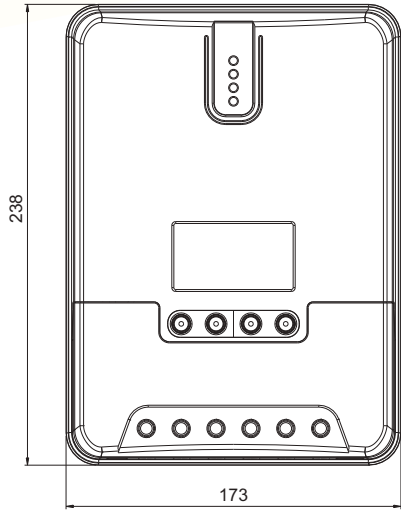

ML2430/ML2440
 Product dimensions : 238*173*72.5mm
 Hole positions : 180*147mm
 Hole diameter : Φ3mm
 Applicable wire: max. 8 AWG

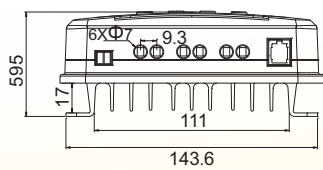
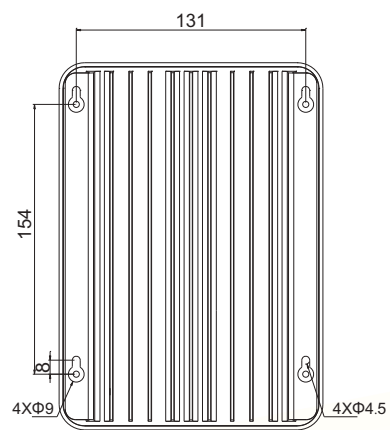
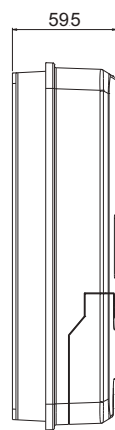
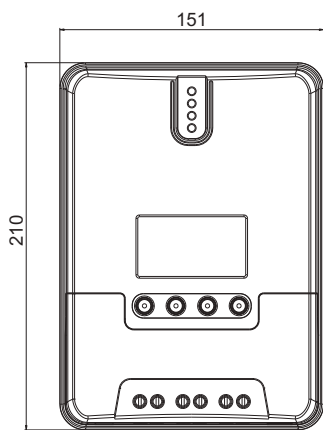

ML2420
 Product dimensions : 210*151*59.5mm
 Hole positions : 154*131mm
 Hole diameter : Φ3mm
 Applicable wire: max. 8 AWG

Product Specification Parameters

1. Electric Parameters

| Parameter | Value | | |
|--------------------------------------|---------------------------|----------------------|-----------------------|
| Model | ML2420 | ML2430 | ML2440 |
| System voltage | 12V/24VAuto | | |
| No-load loss | 0.7 W to 1.2W | | |
| Battery voltage | 9V to 35V | | |
| Max. solar input voltage | 100V(25°C) 90V(-25°C) | | |
| Max. power point voltage range | Battery Voltage+2V to 75V | | |
| Rated charging current | 20A | 30A | 40A |
| Rated load current | 20A | | |
| Max. capacitive load capacity | 10000uF | | |
| Max. photovoltaic system input power | 260W/12V 520W/24V | 400W/12V 800W/24V | 520W/12V 1040W/24V |
| Conversion efficiency | ≤98% | | |
| MPPT tracking efficiency | >99% | | |
| Temperature compensation factor | -3mv/°C/2V (default) | | |
| Operating temperature | -35°C to +45°C | | |
| Protection degree | IP32 | | |
| Weight | 1.4Kg | 2Kg | 2Kg |
| Communication method | RS232 | | |
| Altitude | ≤ 3000m | | |
| Product dimensions | 210*151*59.5mm | 238*173*72.5mm | 238*173*72.5mm |

2. Battery Type Default

Parameters (parameters set in monitor software)

| Parameters cross-reference table for different types of batteries | | | | |
|---|--------------------------|-----------------------|------------------------|--|
| Voltage to set Battery type | Sealed lead-acid battery | Gel lead-acid battery | Open lead-acid battery | User (self-customized) |
| Over-voltage cut-off voltage | 16.0V | 16.0V | 16.0V | 9~17V |
| Equalizing voltage | 14.6V | — | 14.8V | 9~17V |
| Boost voltage | 14.4V | 14.2V | 14.6V | 9~17V |
| Floating charging voltage | 13.8V | 13.8V | 13.8V | 9~17V |
| Boost return voltage | 13.2V | 13.2V | 13.2V | 9~17V |
| Low-voltage cut-off return voltage | 12.6V | 12.6V | 12.6V | 9~17V |
| Under-voltage warning return voltage | 12.2V | 12.2V | 12.2V | 9~17V |
| Under-voltage warning voltage | 12.0V | 12.0V | 12.0V | 9~17V |
| Low-voltage cut-off voltage | 11.1V | 11.1V | 11.1V | 9~17V |
| Discharging limit voltage | 10.6V | 10.6V | 10.6V | 9~17V |
| Over-discharge time delay | 5s | 5s | 5s | 1~30s |
| Equalizing charging duration | 120minutes | — | 120minutes | 0~600minutes |
| Equalizing charging interval | 30days | 0days | 30days | 0~250D (0 means the equalizing charging function is disabled) |
| Boost charging duration | 120minutes | 120minutes | 120minutes | 10~600minutes |

When selecting User, the battery type is to be self-customized, and in this case, the default system voltage parameters are consistent with those of the sealed lead-acid battery. When modifying battery charging and discharging parameters, the following rule must be followed:

- Over-voltage cut-off voltage > Charging limit voltage ≥ Equalizing voltage ≥ Boost voltage ≥ Floating charging voltage > Boost return voltage;
- Over-voltage cut-off voltage > Over-voltage cut-off return voltage;
- Low-voltage cut-off return voltage > Low-voltage cut-off voltage ≥ Discharging limit voltage;
- Under-voltage warning return voltage > Under-voltage warning voltage ≥ Discharging limit voltage;
- Boost return voltage > Low-voltage cut-off return voltage.

